

**UNIVERSAL UNCOMMITTED BACKPLANES, 96-Pin**

Backplanes

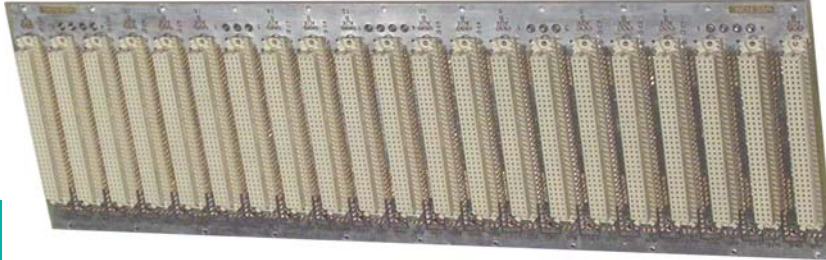

Model UM21A3U-20 Universal (uncommitted) 3U backplane

**3U Backplanes**  
**with 4 Layer Construction**

Universal (uncommitted) multilayer backplanes are designed for unique one of a kind applications requiring custom wiring, or for custom development work. They use 96-pin (press-fit type) connectors and conform to DIN 41612, they have three-level wire-wrap length pins on all connector leads. None of the pin positions are committed to power, ground or signal use; your application will dictate these pin assignments.

These backplanes are designed for maximum utility by incorporating two parallel rows of ground pins (32 pins per row) for each connector slot and two segment of power pins on one row of 6 pins each (total of 12) for +5V (or main voltage) power pins. Two additional voltage levels may be distributed to the board (as AUX A & AUX B) with these power pins conveniently distributed over the board. Power input by means of power bugs and/or Mate-N-Lock connectors are available.

**Features Include:**

- High performance wire-wrap interconnection
- 3U size can combine into 6U or 9U
- Connector spacing of 4HP (0.8") or 6HP (1.2")
- Handles large power requirements (3 oz. copper planes)
- Wide choice of accessories for interconnection

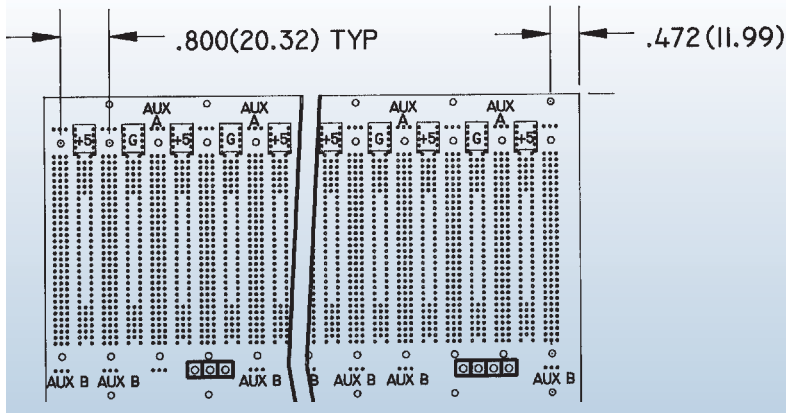

Dwg. A: 3U version with .8" connector spacing. Available with 1.2" spacing.

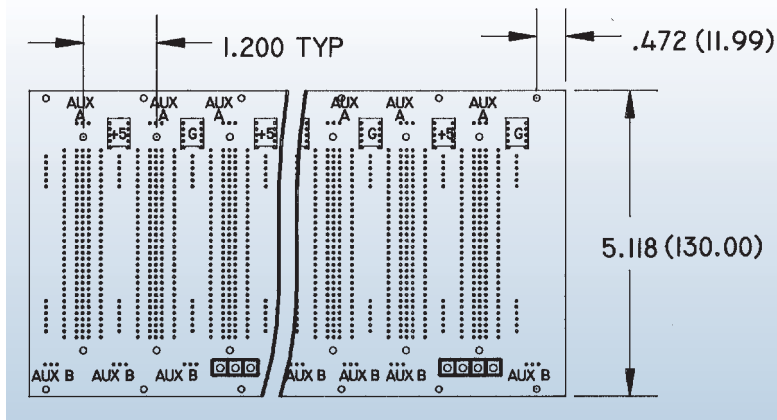

Dwg. B: 3U with 1.2" connector spacing. Available with .8" spacing in 3U. 3U can combine to 6U or 9U.



- Backplane Mounting Hardware  
Each Set includes:
- M2.5 X 12MM Screw
  - #3 Lockwasher
  - M2.5 (DIN#125) Flat Washer
  - HD56-1 42 sets
  - HD56 12 sets



# Vectorbord® Backplanes Uncommitted



## 4 Layer Construction

- Layer 1: Chassis Ground (component side), full coverage on component side; also available on solder side, isolated from circuit ground.
- Layer 2: One or two auxiliary voltages (AUX A and AUX B) can be delivered through Mate-N-Lock connectors; AUX A and AUX B (typically +12V and -12V) accessible through gold-plated wrap power pick-ups - three each at most slot positions.
- Layer 3: Source power is delivered through Mate-N-Lock connectors and/or Power Bug connectors on solder side; +5V is accessible through gold-plated, wire-wrap power pick-up pins - 12 pins available at each slot position.
- Layer 4: Circuit ground (solder side) can be dedicated to chassis ground using pins and solder washers (supplied with backplanes); and is accessible at any pin position and through Mate-N-Lock and Power Bug connectors.
- Full Power Planes - four independent power layers, one can be split between AUX A and AUX B - low impedance power distribution.

GROUND	LAYER 1	3oz
INSULATION		
AUX PWR	LAYER 2	1oz
INSULATION		
POWER	LAYER 3	1oz
INSULATION		
GROUND	LAYER 4	3oz

Backplanes

## Uncommitted Backplane Ordering Table

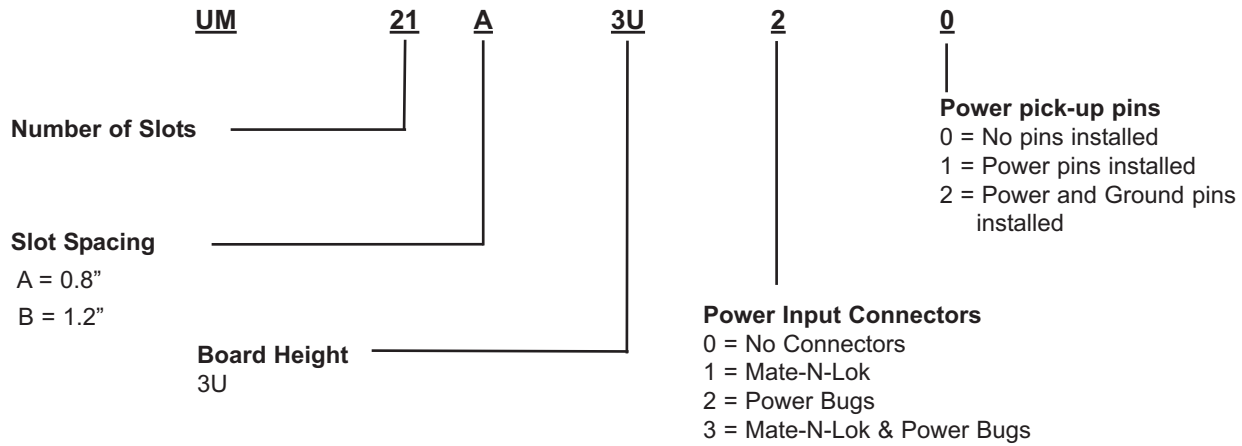

Mating connectors and crimp pins included.

Two 3U Vectorbord® Uncommitted Backplanes installed in 6U DIN Subrack

